

CABC Compatible Four-Channel Backlight Driver with Dual LDO Regulators

General Description

The AAT2868 is a low-noise, constant-frequency charge pump DC/DC converter that uses a dual-mode load switch (1x) and fractional (1.5x) conversion to maximize efficiency for white LED Content Adaptive Brightness Control (CABC) applications. The AAT2868 is capable of driving 4 white LEDs at a total 124mA from a 2.7V to 5.5V input. The current sinks may be operated individually or in parallel for driving higher-current LEDs. A low external parts count (two 1µF flying capacitors and two small 1µF capacitors at IN and OUTCP) makes the AAT2868 ideally suited for small battery-powered applications. The AAT2868 also includes two 150mA low dropout (LDO) linear regulators as additional power supplies for display and related camera power. The LDO voltage is also programmable.

Skyworks' Advanced Simple Serial Control™ (AS²Cwire™) serial digital input is used to enable, disable and set the maximum LED current to one of 32 levels for the LEDs. The current ranges from 31mA to 0.4mA. An external PWM input is adopted to dim the LED current from 100% to 1% of the maximum LED current by varying the PWM duty cycle with frequencies up to 100kHz. To eliminate flicker or noise associated with PWM control, the input PWM signal is filtered to provide a steady state output current.

Each output of the AAT2868 is equipped with built-in protection for short-circuit and auto-disable for load short-circuit conditions. The soft-start circuitry prevents excessive inrush current at charge pump start-up and mode transitions.

The AAT2868 is available in the Pb-free, space-saving TQFN3.0x2.2-18L package, and operates over the -40°C to 85°C ambient temperature range.

Features

- 2.7V to 5.5V Supply Voltage Range
- Charge Pump for LED Driver
 - Dual Mode 1x/1.5x
 - Drives Up to 4 LEDs with up to 31mA each
 - Linear LED Output Control Options
 - Maximum LED Current Set by AS²Cwire Interface, 32 Steps
 - PWM Interface Dimming from 100% to 1% Duty Cycle with Frequency up to 100kHz
- 0.9MHz Constant Frequency
- Automatic Soft-Start Limits Inrush Current
- Dual 150mA LDOs
 - Enable and Output Voltage Set by AS²Cwire Sixteen Combinations of 5 Output Voltages: 1.2V, 1.5V, 1.8V, 2.8V, and 3.0V
 - Integrated Discharge Resistor when Disabled
- < 1.0µA in Shutdown
- Short-Circuit Protection
- Small Application Circuit
- -40°C to 85°C Temperature Range
- RoHS Compliant, Halogen-Free TQFN3.0x2.2-18 Package

Applications

- Camera Phones
- Digital Still Cameras (DSC)
- LED Photo Flash/Torch
- MP3 Players
- PDAs and Notebook PCs
- Smartphones

Typical Application

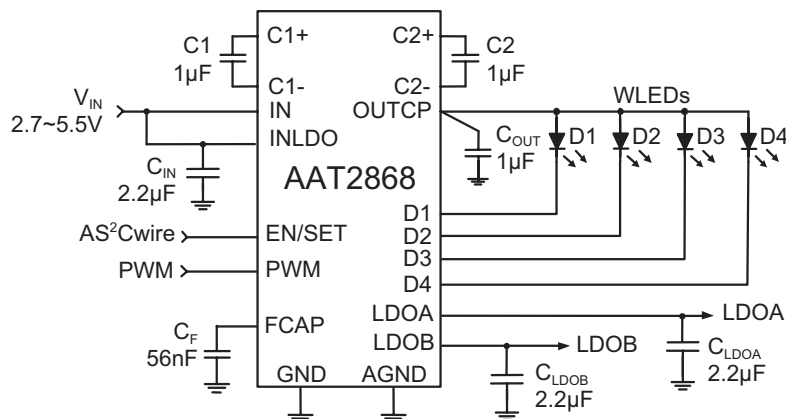

CABC Compatible Four-Channel Backlight Driver with Dual LDO Regulators**Pin Descriptions**

Pin #	Symbol	Function	Description
1	C1+	I	Flying capacitor C1 positive terminal. Connect a 1 μ F capacitor between C1+ and C1-.
2	LDOB	O	LDOB output. Four output voltages can be programmed via the AS ² Cwire interface: 1.2V, 1.5V, 1.8V and 2.5V. The default output voltage is 2.8V.
3	LDOA	O	LDOA output. Four output voltages can be programmed via the AS ² Cwire interface: 1.5V, 1.8V, 2.5V, and 3.0V. The default output voltage is 1.8V.
4	PWM	I	Connect a PWM signal up to 100kHz or tie to GND if PWM is not used.
5	AGND	AG	Analog ground connection.
6	INLDO	P	Input power supply pin to LDOs. Connect this pin to IN. A 1 μ F capacitor is recommended for bypass use from this pin to ground.
7	IN	P	Input power supply pin. Connect a 1 μ F bypass capacitor from this pin to ground.
8	GND	PG	Ground connection.
9	FCAP	I	PWM filter capacitor. Connect a 56nF capacitor to ground. If PWM is not used, leave open.
10	D1	I	LED driver current sink D1. Connect LED cathode to this pin. If not used, tie to OUTCP.
11	D2	I	LED driver current sink D2. Connect LED cathode to this pin. If not used, tie to OUTCP.
12	D3	I	LED driver current sink D3. Connect LED cathode to this pin. If not used, tie to OUTCP.
13	D4	I	LED driver current sink D4. Connect LED cathode to this pin. If not used, tie to OUTCP.
14	EN/SET	I	Charge pump enable/set. When in the low state, AAT2868 is powered down, and consumes less than 1 μ A. When EN/SET jumps from low to high, the charge pump is active and 20mA LED current each are set. The two LDOs remain inactive until data 3 is written to address 4 through the AS ² Cwire interface. This pin should not be left floating.
15	C2-	I	Flying capacitor C2 negative terminal. Connect a 1 μ F capacitor between C1+ and C1-.
16	C2+	I	Flying capacitor C2 positive terminal. Connect a 1 μ F capacitor between C2+ and C2-.
17	OUTCP	O	Charge pump output. Connect a 1 μ F bypass capacitor between this pin and ground.
18	C1-	I	Flying capacitor C1 negative terminal. Connect a 1 μ F capacitor between C2+ and C2-.
EP			Exposed pad. Connect to ground directly beneath the package.

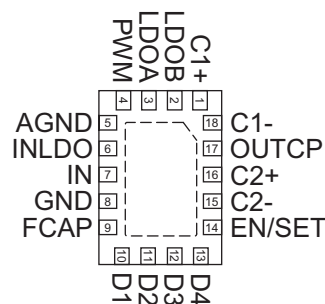
Pin Configurations**TQFN3.0 x 2.2-18
(Top View)**

CABC Compatible Four-Channel Backlight Driver with Dual LDO Regulators**Absolute Maximum Ratings¹**

Symbol	Description	Value	Units
V_{IN}	Input Voltage	-0.3 to 6.0	V
V_{EN}	EN to GND Voltage	-0.3 to 6.0	V
$V_{EN(MAX)}, V_{PWM(MAX)}$	Maximum EN or PWM to Input Voltage or GND	$V_{IN} + 0.3$	V
I_{OUT}	Maximum DC Output Current (continuous) ²	470	mA
T_J	Maximum Junction Operating temperature	-40 to 150	°C
T_{LEAD}	Maximum Soldering Temperature (at leads, 10 sec)	300	

Thermal Information³

Symbol	Description	Value	Units
θ_{JA}	Thermal Resistance from Junction to Ambient	66	°C/W
θ_{JC}	Thermal Resistance from Junction to Case	39	°C/W
P_D	Maximum Power Dissipation	1.5	W

1. Stresses above those listed in Absolute Maximum Ratings may cause permanent damage to the device. Functional operation at conditions other than the operating conditions specified is not implied. Only one Absolute Maximum Rating should be applied at any one time.

2. Based on long-term current density limitation.

3. Mounted on an FR4 board.

CABC Compatible Four-Channel Backlight Driver with Dual LDO Regulators

Electrical Characteristics¹

$V_{IN} = 3.6V$; $C_{IN} = 1\mu F$; $C_{OUT} = 1\mu F$; $C_{FLY} = 1\mu F$; $C_{FLT} = 56nF$; $T_A = -40^\circ C$ to $85^\circ C$, unless otherwise noted. Typical values are $T_A = 25^\circ C$.

Symbol	Description	Conditions	Min	Typ	Max	Units
Input Power Supply						
V_{IN}	Input Voltage Range		2.7		5.5	V
$V_{OUT(MAX)}$	Maximum Output Voltage			5.5		V
I_{CC}	Operating Current	1x Mode, No Load Current, CP enabled		0.5	1	mA
		1.5x Mode, $I_{D1} = FS$, excluding I_{D1} , $V_{D2} = V_{D3} = V_{D4} = IN$		2	4	
$I_{SHDN(MAX)}$	Shutdown Current	EN = 0			1.0	μA
Charge Pump Section						
$I_{OUT(MAX)}$	Maximum Output Current	$V_F = 3.6V$		124		mA
f_{OSC}	Oscillator Frequency			0.9		MHz
t_{SS}	Charge Pump Setup Time			100		μs
$V_{IN_ (TH)}$	Charge Pump Mode Hysteresis	1.5x to 1x Transition, $I_{D1} = I_{D2} = I_{D3} = I_{D4} = 31mA$		300		mV
LED Current Sink Outputs						
I_{DX}	I_{SINK} Current Accuracy ²	Data 32 and PWM = 100%, $T_A = 25^\circ C$	-10		+10	%
		Data 1-3, $T_A = 25^\circ C$		± 15		
$I_{DX(MATCH)}$	Current Marching Between Any Two Current Sinks ³	V_F ; D1:D4 = 3.6V	-5		+5	
$V_{D_ (TH)}$	Charge Pump Mode Transition	1x to 1.5x Mode, $I_{D1} = I_{D2} = I_{D3} = I_{D4} = 31mA$		120	250	mV
AS²Cwire Control and EN/SET Control						
$V_{EN/SET (L)}$	EN/SET				0.4	V
$V_{EN/SET (H)}$	EN/SET		1.4			V
I_{LEAK}	EN/SET Input Leakage		-1		1	mA
$t_{EN/SET(LOW)}$	EN/SET Input Low Time		0.3		75	μs
$t_{EN/SET(HI_MIN)}$	EN/SET Minimum High Time			50		ns
$t_{EN/SET(HI_MAX)}$	EN/SET Maximum High Time				75	μs
$t_{EN/SET(OFF)}$	EN/SET Input Off Timeout ⁴				500	μs
$t_{EN/SET(LAT)}$	EN/SET Latch Timeout ⁵				500	μs
PWM Control						
$V_{PWM(L)}$	PWM Input Low Threshold Voltage				0.4	V
$V_{PWM(H)}$	PWM High Threshold Voltage		1.4			V
$T_{PWM(ON)}$	PWM Turn On Delay				500	μs
$F_{PWM(MIN)}$	PWM Minimum Input Control Frequency		100			Hz
$F_{PWM(MAX)}$	PWM Maximum Input Control Frequency			100		kHz
$F_{PWM(MIN)}$	PWM Minimum Duty Cycle	$F_{PWM} = 50kHz$ full scale	1			%

1. The AAT2868 is guaranteed to meet performance specifications over the $-40^\circ C$ to $+85^\circ C$ operating temperature range and is assured by design, characterization, and correlation with statistical process controls.

2. Determined by the average of all active channels.

3. Current matching is defined as the deviation of any sink current from the average of all active channels.

4. The EN/SET pin must remain logic low (less than V_{IL}) for longer than $500\mu s$ to guarantee the off timeout.

5. The EN/SET pin must remain logic high (greater than V_{IH}) for longer than $500\mu s$ to guarantee the latch timeout.

CABC Compatible Four-Channel Backlight Driver with Dual LDO Regulators**Electrical Characteristics (continued)¹**

$V_{IN} = 3.6V$; $C_{IN} = 1\mu F$; $C_{OUT} = 1\mu F$; $C_{FLY} = 1\mu F$; $C_{FLT} = 56nF$; $T_A = -40^{\circ}C$ to $85^{\circ}C$, unless otherwise noted. Typical values are $T_A = 25^{\circ}C$.

Symbol	Description	Conditions	Min	Typ	Max	Units
Linear Regulators						
$\frac{\Delta V_{OUT[A/B]}}{V_{OUT[A/B]}}$	LDO _A , LDO _B Output Voltage Tolerance	$I_{OUT} = 1mA$ to $150mA$; $T_A = 25^{\circ}C$	-2		2	%
		$I_{OUT} = 1mA$ to $150mA$; $T_A = -40^{\circ}C$ to $+85^{\circ}C$	-3.0		3.0	%
$I_{OUT[A/B](MAX)}$	LDO _A , LDO _B Maximum Load Current		200			mA
$V_{OUT[A/B](DO)}$	LDO _A , LDO _B ²	$V_{OUT[A/B]} \geq 3.0V$; $I_{OUT} = 150mA$		100	150	mV
$\frac{\Delta V_{OUT}}{V_{OUT} * \Delta V_{IN}}$	Line Regulation	$V_{IN} = (V_{OUT[A/B]} + 1V)$ to $5V$		0.09		%/V
$PSRR_{[A/B]}$	LDO _A , LDO _B Power Supply Rejection Ratio	$I_{OUT[A/B]} = 10mA$, $1kHz$		50		dB
$R_{OUT(DCHG)}$	LDO _A , LDO _B Auto-Discharge Resistance			720		Ω
Thermal						
T_{SD}	T_J Thermal Shutdown Threshold			140		$^{\circ}C$
T_{HYS}	T_J Thermal Shutdown Hysteresis			20		$^{\circ}C$

1. The AAT2868 is guaranteed to meet performance specifications over the $-40^{\circ}C$ to $+85^{\circ}C$ operating temperature range and is assured by design, characterization, and correlation with statistical process controls.

2. $V_{DO[A/B]}$ is defined as $V_{IN} - LDO[A/B]$ when LDO[A/B] is 98% of nominal.

CABC Compatible Four-Channel Backlight Driver with Dual LDO Regulators

Typical Characteristics

CP Operating Current vs. Input Voltage
(1x Mode)

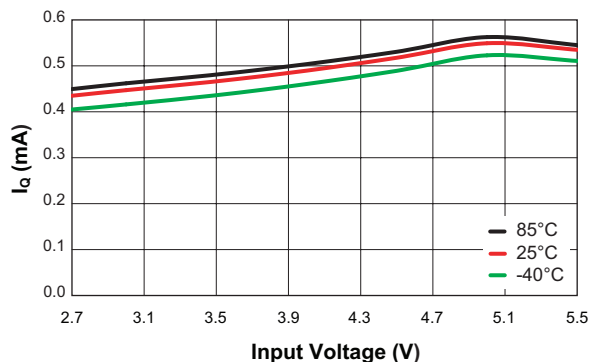

CP Operating Current vs. Input Voltage
(1.5x Mode)

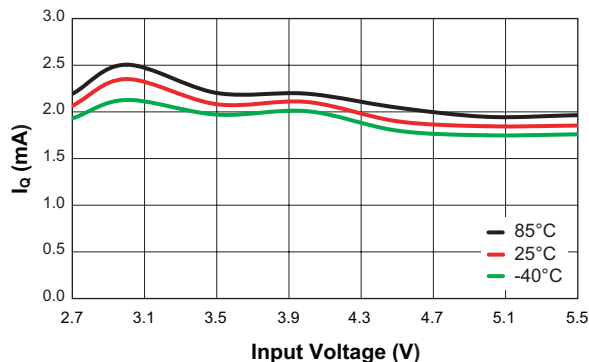

CP Input Current vs. Input Voltage

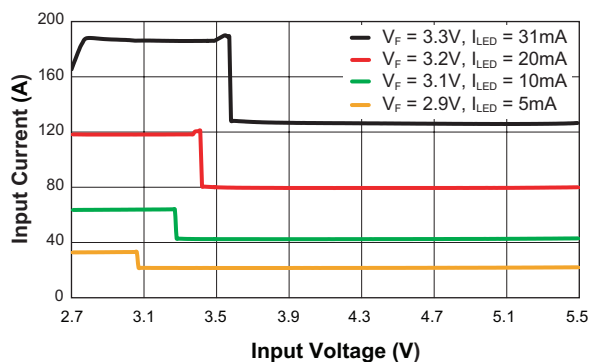

Shutdown Current vs. Temperature

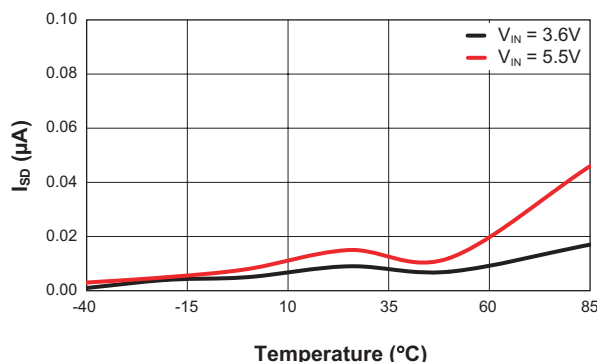

LDO Operating Current vs. Input Voltage
(LDOA + LDOB)

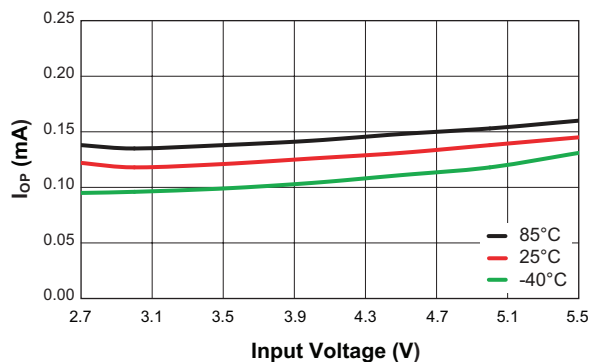

LDO Operating Current vs. Input Voltage
(LDOA Only)

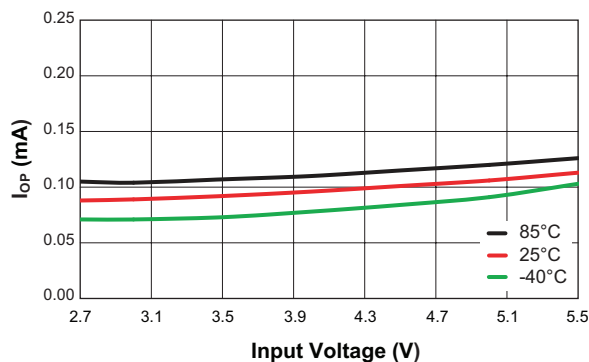

CABC Compatible Four-Channel Backlight Driver with Dual LDO Regulators

Typical Characteristics

CP Efficiency vs. Input Voltage

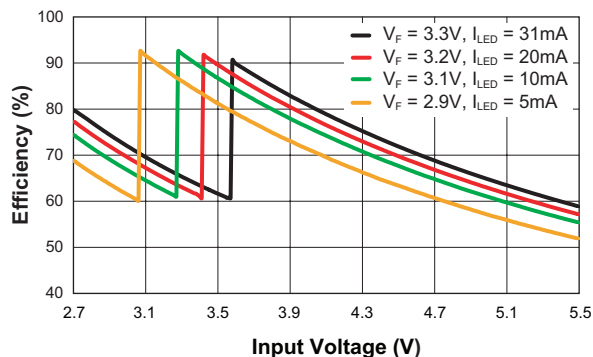

Frequency vs. Temperature

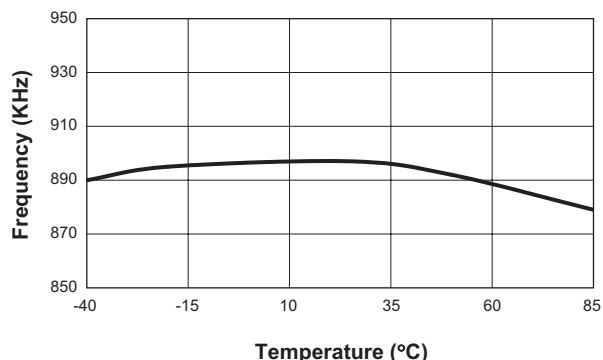

CP Current Matching vs. Temperature
($V_{IN} = 3.6V; V_F = 3.3V; 31mA/ch$)

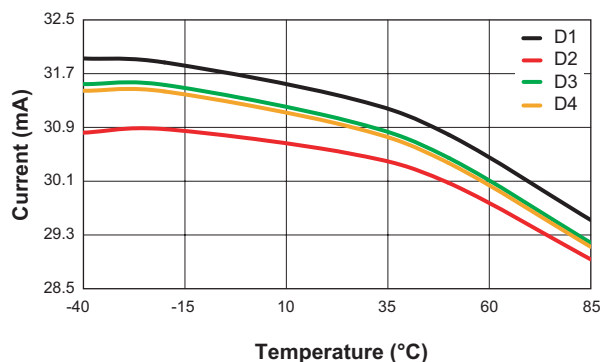

CP Current Matching vs. Temperature
($V_{IN} = 3.6V; V_F = 3.3V; 0.5mA/ch$)

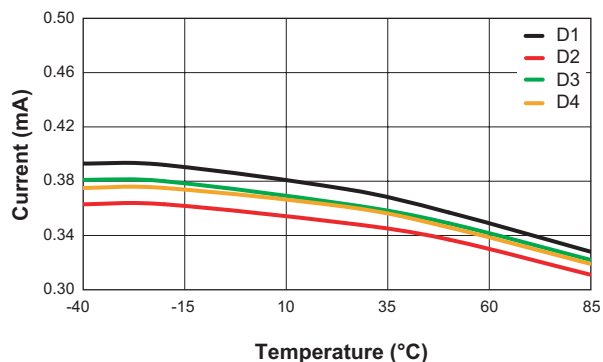

LDO Line Regulation vs. Input Voltage
($V_{OUT} = 1.2V$)

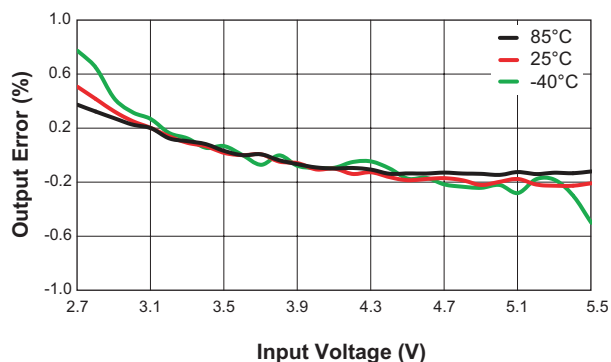

LDO Load Regulation vs. Output Current
($V_{OUT} = 1.2V$)

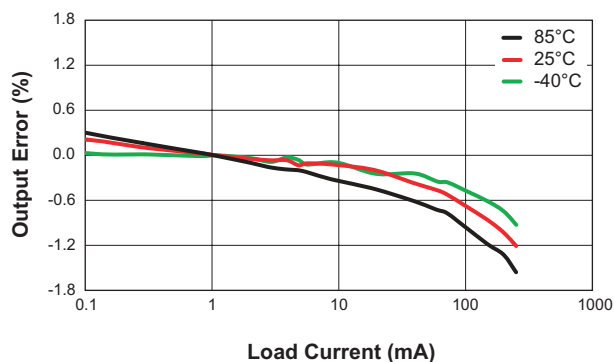

CABC Compatible Four-Channel Backlight Driver with Dual LDO Regulators

Typical Characteristics

EN Input High Threshold Voltage vs. Input Voltage

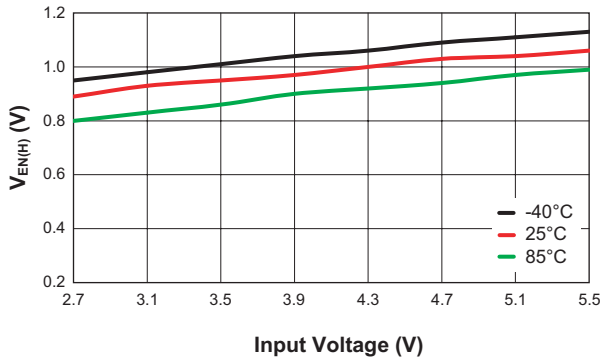

EN Input Low Threshold Voltage vs. Input Voltage

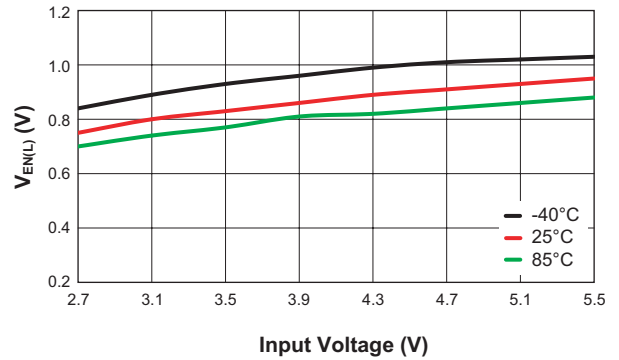

PWM Input High Threshold Voltage vs. Input Voltage

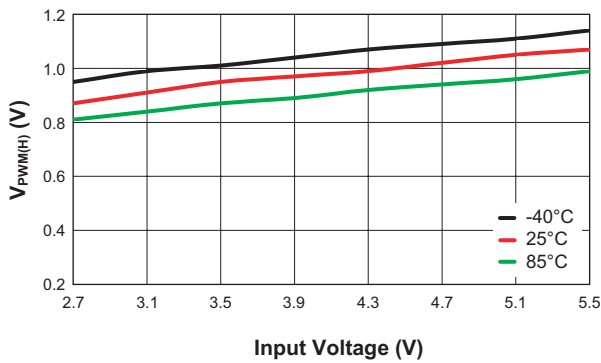

PWM Input Low Threshold Voltage vs. Input Voltage

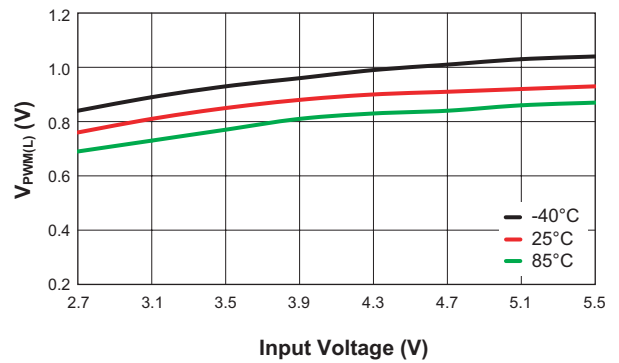

EN/SET Input Latch Time vs. Input Voltage

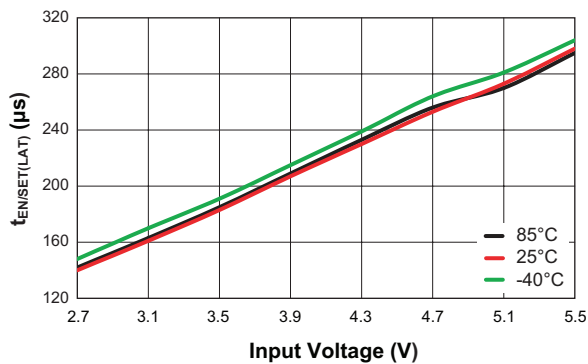

EN/SET Input Off Time vs. Input Voltage

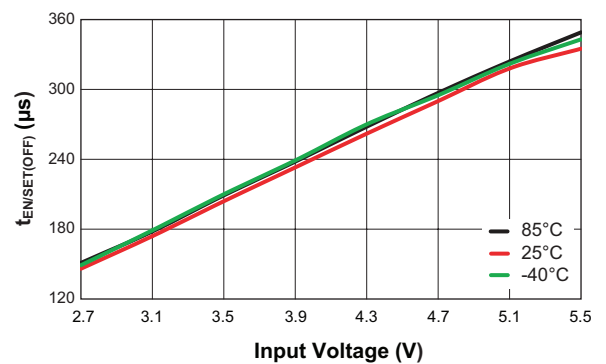

CABC Compatible Four-Channel Backlight Driver with Dual LDO Regulators

Typical Characteristics

CP Turn On

($V_{IN} = 3.6V$; $C_{IN} = C_{OUT} = 1\mu F$; $C_F = 56nF$; 20mA/ch)

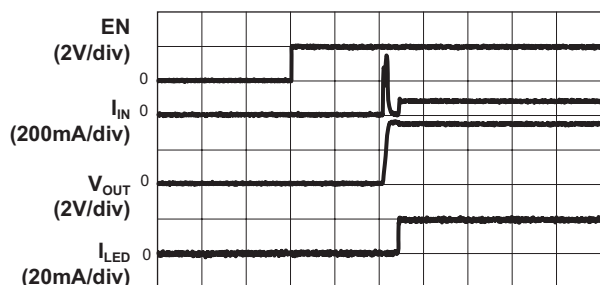

Time (100 μs /div)

CP Turn Off

($V_{IN} = 3.6V$; $C_{IN} = C_{OUT} = 1\mu F$; $C_F = 56nF$; 31mA/ch)

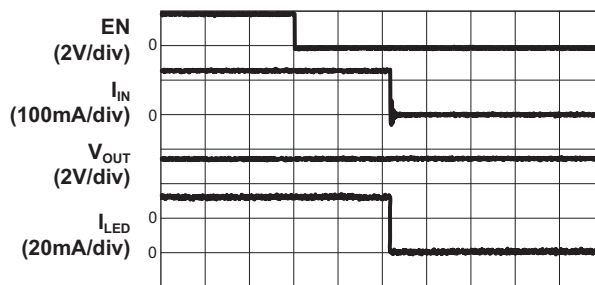

Time (100 μs /div)

CP Current Transient

($V_{IN} = 3.6V$; 0.5mA to 31mA)

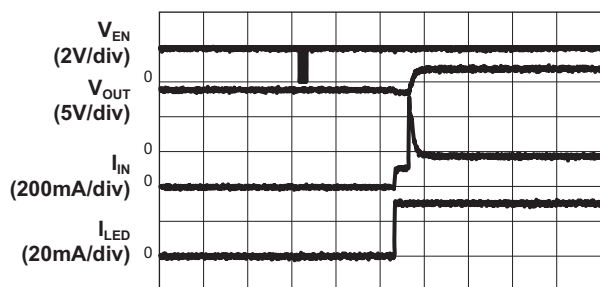

Time (100 μs /div)

CP Current Transient

($V_{IN} = 3.6V$; 31mA to 0.5mA)

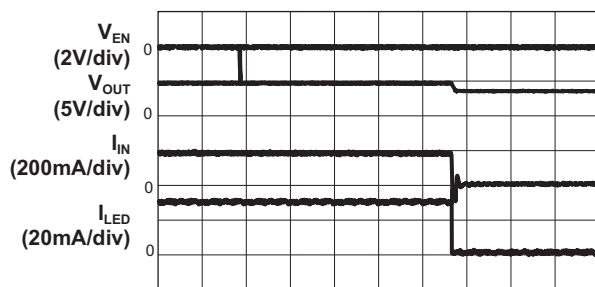

Time (40 μs /div)

LDO Turn On

($V_{IN} = 3.6V$; $C_{IN} = 2.2\mu F$; $C_{LDOA} = C_{LDOB} = 2.2\mu F$;
 $V_{LDOA} = 2.8V$; $V_{LDOB} = 1.2V$)

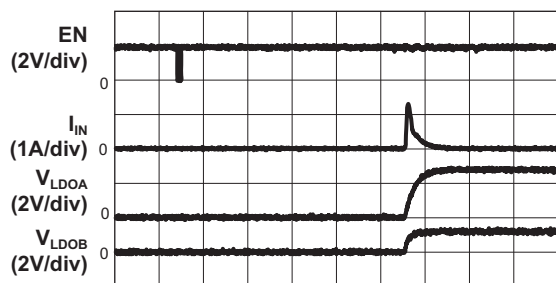

Time (40 μs /div)

LDO Turn On

($V_{IN} = 3.6V$; $C_{IN} = 2.2\mu F$; $C_{LDOA} = C_{LDOB} = 2.2\mu F$;
 $V_{LDOA} = 3.0V$; $V_{LDOB} = 1.8V$)

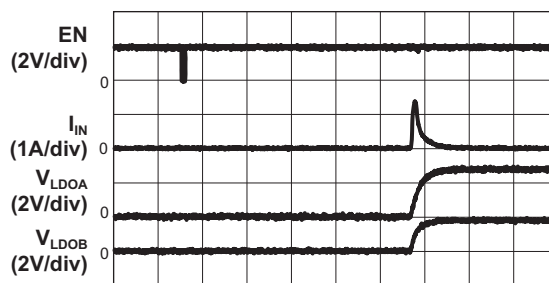

Time (40 μs /div)

CABC Compatible Four-Channel Backlight Driver with Dual LDO Regulators

Typical Characteristics

LDO Turn Off

($V_{IN} = 3.6V$; $C_{IN} = 2.2\mu F$; $C_{LDOA} = C_{LDOB} = 2.2\mu F$;
 $V_{LDOA} = 2.8V$; $V_{LDOB} = 1.2V$)

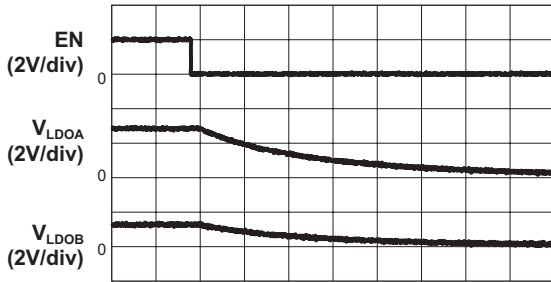

Time (1ms/div)

1.5x Mode Operating Characteristics

($V_{IN} = 3.2V$; $C_{IN} = C_{OUT} = 1\mu F$; 31mA/ch)

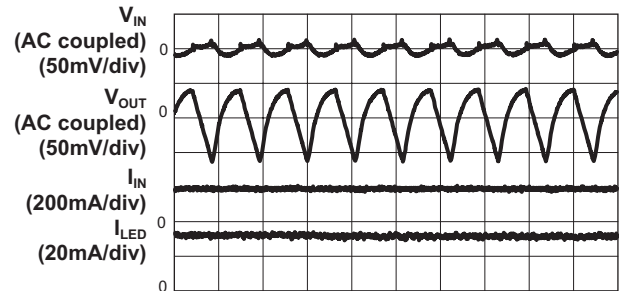

Time (1µs/div)

1.5x Mode Operating Characteristics

($V_{IN} = 3.2V$; $C_{IN} = C_{OUT} = 1\mu F$; PWM;
 100kHz; Duty = 50%; 31mA/ch)

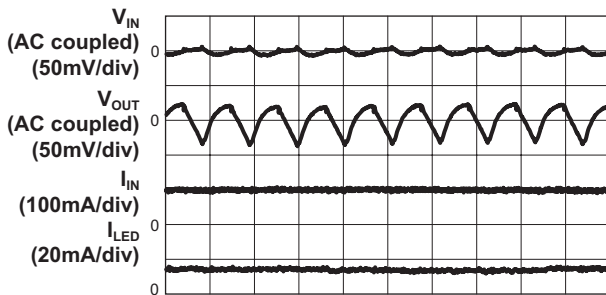

Time (1µs/div)

CP Mode Transient

($V_{IN} = 3.6V$ to $4.2V$; $C_{IN} = C_{OUT} = 1\mu F$; 31mA/ch)

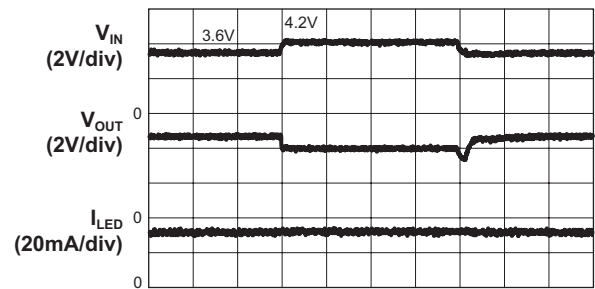

Time (100µs/div)

LDO Load Transient

($V_{IN} = 3.6V$; $V_{OUTB} = 1.2V$; $C_{IN} = C_{OUTB} = 2.2\mu F$;
 10mA to 150mA)

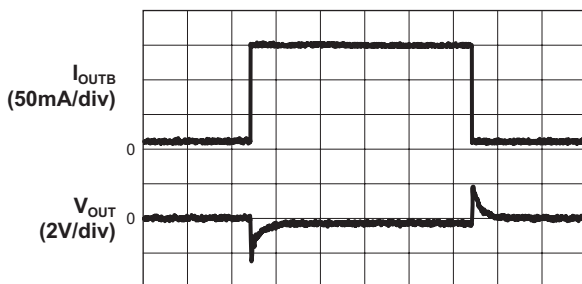

Time (40µs/div)

CABC Compatible Four-Channel Backlight Driver with Dual LDO Regulators

Typical Characteristics

Dropout Characteristics
($V_{OUTA} = 2.8V$)

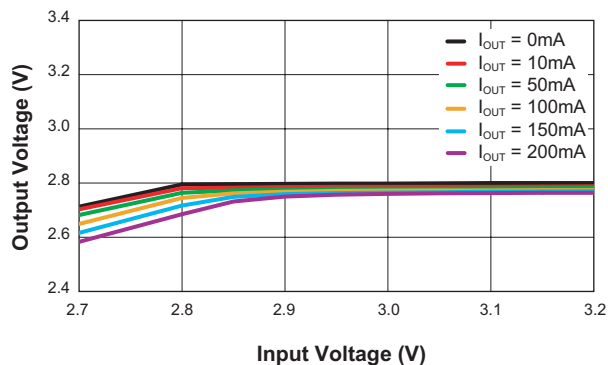

Dropout Characteristics
($V_{OUTA} = 3.0V$)

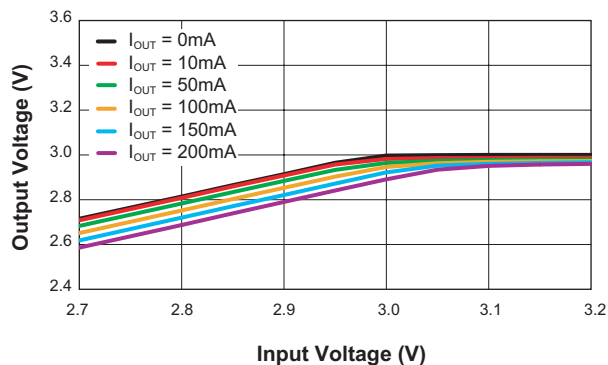

PSRR vs. Frequency

($V_{IN} = 3.6V$, $V_{RIPPLE} = 500mVPP$, $C_{IN} = C_{OUT} = 2.2\mu F$, $I_L = 10mA$)

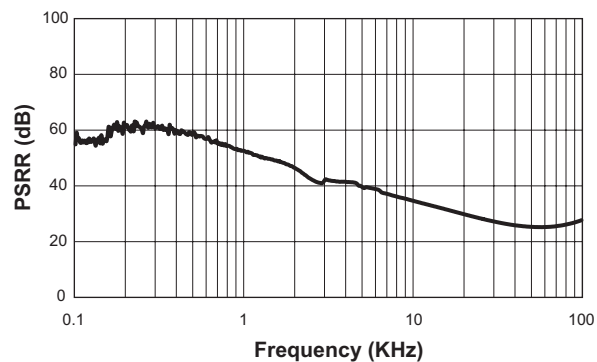

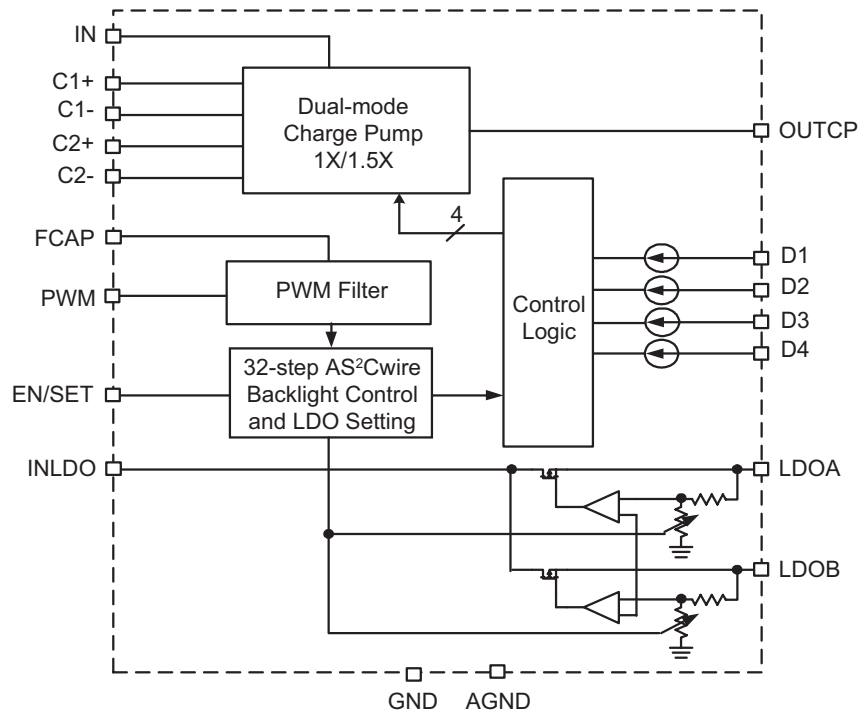
CABC Compatible Four-Channel Backlight Driver with Dual LDO Regulators**Functional Block Diagram****Functional Description**

The AAT2868 is a high efficiency charge pump white LED driver for portable applications. It can drive up to 4 white LEDs. And the integrated two LDOs can provide 1.2V, 1.5V, 1.8V, 2.8V and 3.0V output voltages with 16 combinations with up to 150mA load capability.

The charge pump of AAT2868 is a fractional charge pump and can multiply the input voltage by 1 or 1.5 times. The charge pump switches at a fixed frequency of 0.9MHz. The internal mode-selection circuit automatically switches the mode between 1x and 1.5x based on the input voltage, white LED forward voltage V_f , and the programmed LED current. This mode switching maximizes the efficiency throughout the entire LED load range. When the input voltage is high enough, the charge pump operates in 1x mode (no charge pump) to provide maximum efficiency. If the input voltage is too low to supply the programmed LED current, typically when the battery discharges and the voltage decays, the 1.5x charge pump mode is automatically enabled. When the battery is connected to a charger and the input voltage become high enough again, the device will switch back to 1x mode.

Five registers are designed for charge pump enable/disable control, LED current programming, LDO enable/disable control of the two LDOs, and combined LDO output voltage settings via the AS²Cwire interface. The LED current value is controlled by either the AS²Cwire interface, a PWM interface, or both. The AS²Cwire interface records rising edges of the EN/SET pin and decodes them into 32 individual current level settings from 0.4mA to 31mA, while the PWM interface receives an input switching frequency where the duty cycle is varied to modulate the output current. To avoid switching noise and flicker in the output LED, the input PWM frequency is filtered via an internal resistor and small external capacitor to provide a constant LED current. Once the AAT2868 charge pump is enabled, the PWM input will modulate the current up to the maximum current programmed by the AS²Cwire interface.

AS²C Registers

The AAT2628 has five registers with up to four bits each to control the LED backlighting enable/disable, LED current and two LDOs enable/disable, output voltages, etc. as shown in Table 1. Each register data can be written

CABC Compatible Four-Channel Backlight Driver with Dual LDO Regulators

Address		Function	Data				EN/SET Rising Edges
Number	EN/SET Rising Edges		D3	D2	D1	D0	
0 [Default]	17	Backlight Enable	0	BL_ENB	0	0	1 or 5
1	-	Reserved	-	-	-	-	-
2	19	Backlight MSB	0	0	0	BL[4]	1 or 2
3	20	Backlight LSBs	BL[3]	BL[2]	BL[1]	BL[0]	1 ~ 16
4	21	LDO Enable Control	0	0	LDOA_EN	LDOB_EN	1 ~ 4
5	22	LDO Output Voltage	LDO[3]	LDO[2]	LDO[1]	LDO[0]	1 ~ 16

Table 1: AAT2868 AS²C Registers.

with 1 to 16 EN/SET rising edges. Some bits are internally reserved and customer should only write it by bit zero, such as Address 0, bit D0, D1 and D3, etc. Otherwise it may lead to unexpected result. Address 0 is the default address; if EN/SET is pulled high after a low level of at least 500 μ s t_{OFF} duration, address 0 is written by 0 and LED backlighting is enabled with the default 20mA LED current each.

Address 0 – Backlight Enable

The BL_ENB bit of address register 0 is adopted to enable or disable white LED backlighting. 0 enables backlighting; 1 disables backlighting. The other bits of the register should be written by zero.

Description	BL_ENB
Backlight On [default]	0
Backlight Off	1

Table 2: AS²C Register Address 0 Settings.**Address 2 and 3 – LED Current Level Settings**

LED current level is set via the AS²Cwire interface in a linear scale by 32 codes where LED current of each higher code is higher than the lower one, as shown in Table 2. In this manner, the LED current decreases linearly with each decreasing code.

LED Current Codes	Addr2	Addr3				LED Current (mA)
	BL4	BL3	BL2	BL1	BL0	
1	0	0	0	0	0	0.4
2	0	0	0	0	1	0.9
3	0	0	0	1	0	1.9
4	0	0	0	1	1	2.9
5	0	0	1	0	0	3.9
6	0	0	1	0	1	4.9
7	0	0	1	1	0	6.0
8	0	0	1	1	1	7.0
9	0	1	0	0	0	8.0
10	0	1	0	0	1	9.0
11	0	1	0	1	0	10.0
12	0	1	0	1	1	11.0
13	0	1	1	0	0	12.0
14	0	1	1	0	1	13.0
15	0	1	1	1	0	14.0
16	0	1	1	1	1	15.0
17	1	0	0	0	0	16.0
18	1	0	0	0	1	17.0
19	1	0	0	1	0	18.0
20	1	0	0	1	1	19.0
21	1	0	1	0	0	20.0 [Default]
22	1	0	1	0	1	21.0
23	1	0	1	1	0	22.0
24	1	0	1	1	1	23.0
25	1	1	0	0	0	24.0
26	1	1	0	0	1	25.0
27	1	1	0	1	0	26.0
28	1	1	0	1	1	27.0
29	1	1	1	0	0	28.0
30	1	1	1	0	1	29.0
31	1	1	1	1	0	30.0
32	1	1	1	1	1	31.0

Table 3: AS²C Register Address 2 and Address 3 LED Current Settings¹.

1. The LED current accuracy is compromised at low code settings.

CABC Compatible Four-Channel Backlight Driver with Dual LDO Regulators**Address 4 – LDO Enable Control**

The AAT2868 includes two low dropout (LDO) linear regulators. These regulators are powered from the battery and produce a fixed output voltage set through the AS²Cwire serial interface. AS²C address 4 register is used to turn the two LDOs on/off via the AS²Cwire serial interface. An internal resistor is used to discharge the LDO output voltage when the LDO is disabled.

Description	Data		EN/SET Rising Edges
	LDOA_EN	LDOB_EN	
LDOA Off, LDOB Off [Default]	0	0	1
LDOA Off, LDOB On	0	1	2
LDOA On, LDOB Off	1	0	3
LDOA On, LDOB On	1	1	4

Table 4: AS²C Register Address 4 Settings.**Address 5 - LDO Voltage Output Settings**

Register address 5 is used to set LDOA and LDOB output voltage levels. Sixteen combinations of the two LDOs can be programmed by the 4 bits of the register. LDOA can be set to one of four levels: 1.5V, 1.8V, 2.8V or 3.0V. LDOB can be set one of four levels: 1.2V, 1.5V, 1.8V or 2.8V. The LDO regulators require only a small 2.2μF ceramic output capacitor for stable operation. If improved load transient response is required, larger-valued capacitors can be used without stability degradation.

AS²Cwire EN/SET Interface

The AAT2868 is dynamically programmable using the AS²Cwire single-wire interface. AS²Cwire records rising edges detected at the EN/SET pin to address and load the data registers. The timing diagram in Figure 1 shows the typical transmission protocol.

Description	Data				EN/SET Rising Edges
	LDO[3]	LDO[2]	LDO[1]	LDO[0]	
LDOA = 3.0V, LDOB = 2.8V	0	0	0	0	1
LDOA = 3.0V, LDOB = 1.8V	0	0	0	1	2
LDOA = 3.0V, LDOB = 1.5V	0	0	1	0	3
LDOA = 3.0V, LDOB = 1.2V	0	0	1	1	4
LDOA = 2.8V, LDOB = 2.8V	0	1	0	0	5
LDOA = 2.8V, LDOB = 1.8V	0	1	0	1	6
LDOA = 2.8V, LDOB = 1.5V	0	1	1	0	7
LDOA = 2.8V, LDOB = 1.2V	0	1	1	1	8
LDOA = 1.8V, LDOB = 2.8V [default]	1	0	0	0	9
LDOA = 1.8V, LDOB = 1.8V	1	0	0	1	10
LDOA = 1.8V, LDOB = 1.5V	1	0	1	0	11
LDOA = 1.8V, LDOB = 1.2V	1	0	1	1	12
LDOA = 1.5V, LDOB = 2.8V	1	1	0	0	13
LDOA = 1.5V, LDOB = 1.8V	1	1	0	1	14
LDOA = 1.5V, LDOB = 1.5V	1	1	1	0	15
LDOA = 1.5V, LDOB = 1.2V	1	1	1	1	16

Table 5: AS²Cwire Register Address 5 LDOA and LDOB Output Voltage Settings.

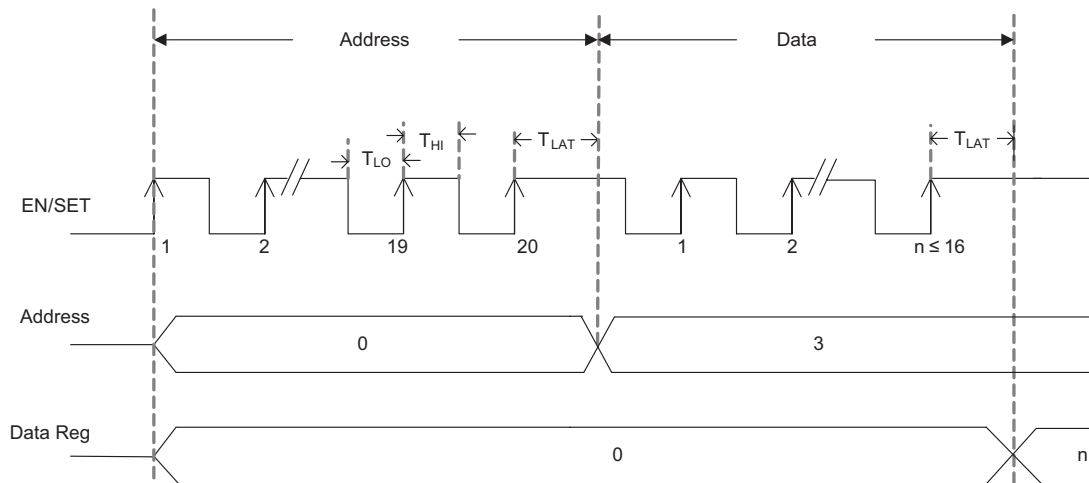
CABC Compatible Four-Channel Backlight Driver with Dual LDO Regulators**Figure 1: AS²Cwire Timing Diagram.**

The AAT2868 latches address or data after the EN/SET input has been held high for time t_{LAT} (500 μ s) through AS²Cwire interface. Address or data is differentiated by the number of EN/SET rising edges. Address has EN/SET rising edges from 17 to 22 and data has EN/SET rising edges from 1 to 16. A typical write protocol of the AS²Cwire interface is a burst of EN/SET rising edges identifying a particular address, followed by a pause with EN/SET held high for the t_{LAT} timeout period, then a burst of rising edges signifying data, and another t_{LAT} timeout after the data has been sent. Once an address is set, multiple writes to that address are allowed since the address is not reset after each write. Address edges are needed when changing the address, or writing to an address other than the default after shutdown. Address 0 is the default address after shutdown. If the part is enabled with only one rising edge after shutdown, then Address 0 will be programmed and LED backlight channels BL1-BL4 will be enabled to the default 20mA each.

When EN/SET is held low for a time longer than t_{OFF} (500 μ s), the AAT2868 enters shutdown mode with charge pump and two LDOs all turning off and draws less than 1 μ A of current from IN. At shutdown, the data and address registers are reset to 0.

PWM Control

The AAT2868 also includes an independent 20mA LED current PWM dimming control with EN/SET low or an additional means of providing dimming control after maximum LED current set by EN/SET. When EN/SET is

low, up to 100kHz PWM signal with varied duty cycle through PWM pin may change the LED current between 0mA and 20mA each.

When PWM is used as an additional dimming control, before the PWM signal is activated, the EN/SET pin must be held for the t_{LAT} period after setting the maximum current available to the LEDs. For example, if the maximum current of 20mA is required then a simple enable of the EN/SET followed by t_{LAT} will allow 20mA to flow through each LED. By applying a variable duty cycle between 1% and 100% on the PWM pin, this current can now be adjusted. Frequencies of up to 100kHz can be applied. To avoid output flicker and noise, the input control PWM frequency is filtered by an internal resistor in conjunction with an external filter capacitor. It is recommended that a 56nF ceramic capacitor be used.

Short Circuit and Over-Temperature Protection

The AAT2868 integrates short circuit protection to limit the input current in the case of the charge pump output or the two LDO outputs shorted to ground by fault. The backlight and the two LDOs will recover to normal operating state once the fault is removed.

The AAT2868 also includes over-temperature protection circuitry. When the junction temperature is too high, the over-temperature protection circuitry is active and the IC enters standby mode with no LED current or LDO output. When the fault is removed, the LED backlighting and LDO outputs all recover.

CABC Compatible Four-Channel Backlight Driver with Dual LDO Regulators

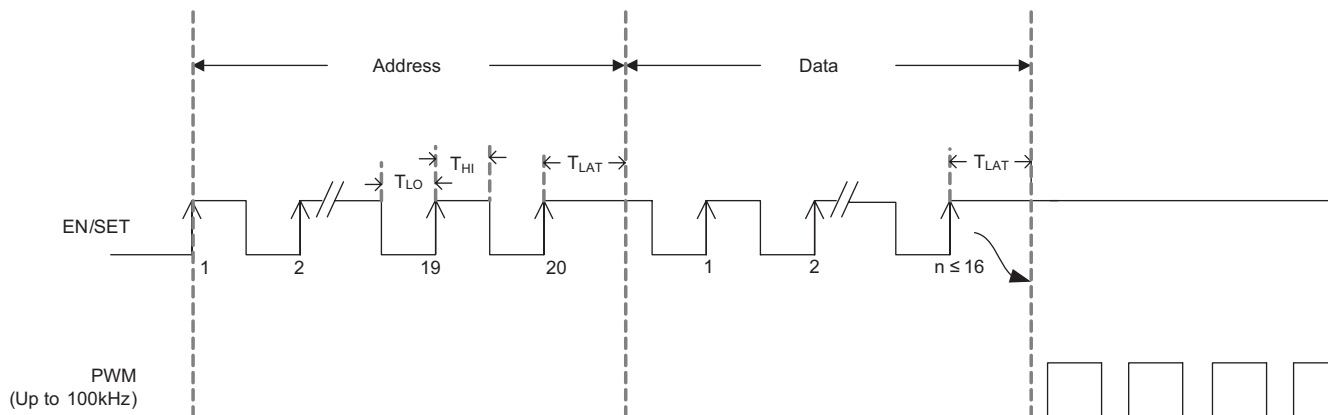

Figure 2: PWM Control Timing

Application Information

LED Selection

The AAT2868 is designed to drive high intensity white flash LEDs with forward voltages up to 4.4V. Though AAT2868 switches the charge pump mode 1x and 1.5x mode automatically to maintain the continuous LED current accuracy, to obtain higher efficiency lower V_F of the white LEDs should be selected.

Maximum LED Current Setting

32 maximum LED current codes from 0.4mA to 31mA can be set by address registers 2 and 3 through the EN/SET AS²Cwire interface as shown in Figure 3. To obtain linear LED current change, the AAT2868 is designed not to change the LED current when data is written only to address 2. The control circuit writes data to both address

2 and address 3 registers only after address 3 is written to determine which LED current code is programmed. Address 2 BL4's default value is 0 after one EN/SET rising edge.

Code 1 to 16 with LED current from 0.4mA to 15mA can be set after sending address 3 with 20 rising edges and sending data with 1 to 16 rising edges after t_{LAT} . Code 17 to 32 with LED current from 16mA to 31mA can be obtained after writing both address 2 and address 3. The operation is performed via the following steps:

1. Select address 2 by sending 19 rising edges on EN/SET and holding high for t_{LAT} ;
2. Send data 1 to set DL4 by sending 2 rising edges and holding high for t_{LAT} ;
3. Select address 3 by sending 20 rising edges on EN/SET and holding high for t_{LAT} ;
4. Send data 15 to obtain LED current code 32 setting by sending 16 rising edges on EN/SET and holding high for t_{LAT} .

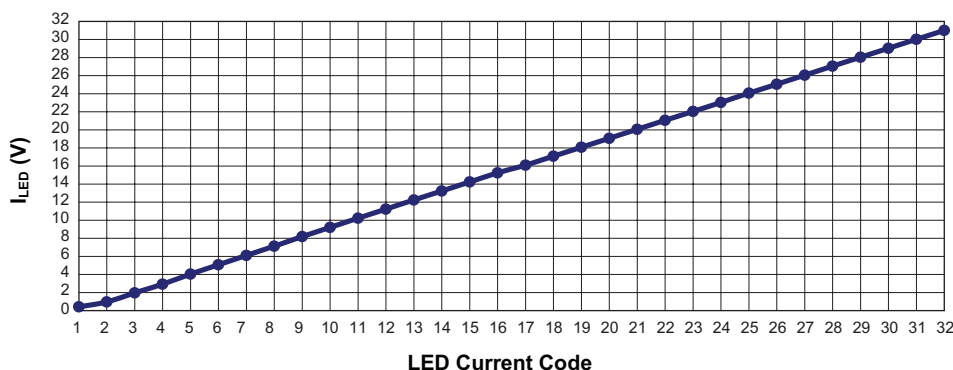

Figure 3: AAT2868 Total 32 LED Current Codes vs. LED Current.

CABC Compatible Four-Channel Backlight Driver with Dual LDO Regulators

LED Dimming by PWM

The external PWM input signal dims the LEDs linearly by varying the duty cycle from 100% to 1%. Figure 4 shows the varied PWM duty cycle vs. maximum 20mA LED current.

C_{FLT} is used as a RC filter capacitor to filter the PWM control signal to a constant voltage for internal LED current control. With internal resistance of 200k Ω and the RC filter rejection frequency set to 1/20 of the PWM frequency, the C_{FLT} minimum value can be calculated by the following formula:

$$C_{FLT} = \frac{20}{2\pi R \cdot f_{PWM}}$$

Table 7 shows some minimum C_{FLT} values for different PWM frequencies. For most applications, 56nF is a suitable value except for 100Hz PWM frequency where a value greater than 160nF should be used. If PWM control is not used, C_{FLT} is unnecessary.

f_{PWM} (kHz)	Minimum C_{FLT} (nF)
0.1	159
1	15.9
10	1.6
30	0.5
50	0.3
80	0.2
100	0.2

Table 7: Minimum C_{FLT} Value Examples.

Charge Pump Efficiency

1x Mode Efficiency

The AAT2868's 1x mode is operational at all times and functions alone to enhance device power conversion efficiency when V_{IN} is higher than the voltage across the load. When in 1x mode, voltage conversion efficiency is defined as output power divided by input power.

$$\eta = \frac{P_{OUT}}{P_{IN}}$$

An expression for the ideal efficiency (η) in 1X charge pump mode can be expressed as:

$$\eta = \frac{P_{OUT}}{P_{IN}} = \frac{V_F \cdot I_{OUT}}{V_{IN} \cdot I_{IN}} \approx \frac{V_F}{V_{IN}}$$

-or-

$$\eta(\%) = 100 \left(\frac{V_{OUT}}{V_{IN}} \right)$$

1.5x Charge Pump Mode Efficiency

The AAT2868 contains a fractional charge pump which will boost the input supply voltage in the event where V_{IN} is less than the voltage required to supply the output. The efficiency (η) can be simply defined as a linear voltage regulator with an effective output voltage that is equal to one and one half times the input voltage. Efficiency (η) for an ideal 1.5x charge pump can be calculated by the following equation:

$$\eta = \frac{P_{OUT}}{P_{IN}} = \frac{V_F \cdot I_{OUT}}{V_{IN} \cdot I_{IN}} = \frac{V_F \cdot I_{OUT}}{V_{IN} \cdot 1.5 \cdot I_{OUT}} \approx \frac{V_F}{1.5 \cdot V_{IN}}$$

-or-

$$\eta(\%) = 100 \left(\frac{V_{OUT}}{1.5 \cdot V_{IN}} \right)$$

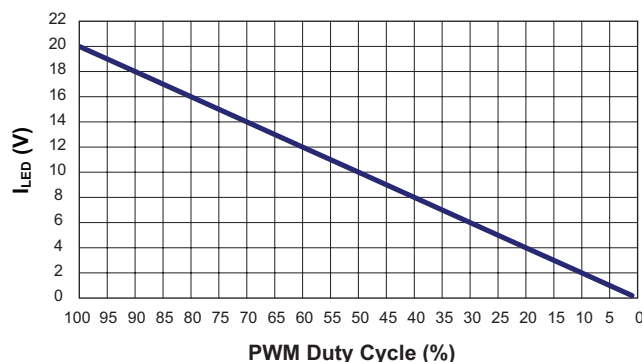

Figure 4: Linear Dimming by PWM Duty Cycle (20mA Maximum LED Current).

CABC Compatible Four-Channel Backlight Driver with Dual LDO Regulators**Capacitor Selection**

The AAT2868 needs seven capacitors for a typical application: C_{IN} , C_{OUT} , C_1 , C_2 , C_{FLT} and C_{LOA} , C_{LOB} . Among them, C_{IN} , C_1 , C_2 and C_{OUT} are required for the 1.5x mode charge pump. 1 μ F surface-mount multi-layer ceramic capacitors with less than 100m Ω low equivalent series resistance (ESR) are recommended. Though capacitor ESR will not affect the ability of the capacitor to store energy, it has a large effect on performance such as equivalent output resistance, efficiency, and output voltage ripple of the charge pump. Tantalum and aluminum electrolytic capacitors are not recommended for use with the AAT2868 due to their high ESR. A output capacitance value of 2.2 μ F or above is required for LDOA and LDOB for proper load voltage regulation and stable operation. Table 6 shows some recommended capacitors.

For most applications, ceramic capacitors with X5R temperature characteristics are preferred for AAT2868 application. These capacitors have good capacitance tolerance over a wide temperature range (X5R: $\pm 15\%$ over -55°C to $+85^{\circ}\text{C}$). Capacitors with Y5V or Z5U temperature characteristics are generally not recommended for AAT2868. They have wide capacitance tolerance over special temperature (Y5V: $+22\%$, -82% over -30°C to $+85^{\circ}\text{C}$, Z5U: $+22\%$, -56% over $+10^{\circ}\text{C}$ to $+85^{\circ}\text{C}$).

Careful selection of the four external capacitors C_{IN} , C_1 , C_{OUT} is important because they will affect turn-on time, output ripple and transient performance. Optimum per-

formance will be obtained when low ESR ($<100\text{m}\Omega$) ceramic capacitors are used. In general, low ESR may be defined as less than 100m Ω . A capacitor value of 1 μ F for all four capacitors is a good starting point when choosing capacitors. If the LED current sinks are only programmed for light current levels, then the capacitor size may be decreased.

Additional Applications

The current sinks of the AAT2868 can be combined to drive higher current levels through a single LED. As an example, Figure 5 shows the AAT2868 driving a single white LED with up to 124mA by connecting D1-D4 together to the LED cathode.

Printed Circuit Board Layout Recommendations

When designing a PCB for the AAT2868, the key requirements are:

1. Place the flying capacitors C1 and C2 as close to the chip as possible; otherwise 1.5x mode performance will be compromised.
2. Place input and output decoupling capacitors as close to the chip as possible to reduce switching noise and output ripple.
3. Connect the exposed pad to GND plane to get best power dissipation.

Manufacturer	Part Number	Value (μF)	Voltage	Temp. Co.	ESR ($\text{m}\Omega$) at 1MHz	Case
Murata	GRM188R61C105KA93	1	16	X5R	18	0603
	GRM185R60J105KE21	1	6.3	X5R	16	0603
	GRM188R61A225KE34	2.2	10	X5R	12	0603
TDK	C1608X5R1C105K	1	16	X5R	5.5	0603
	C1608X5R0J225K	2.2	6.3	X5R	3.3	0603

Table 6: AAT2868 Recommended Capacitors.

AAT2868

CABC Compatible Four-Channel Backlight Driver with Dual LDO Regulators

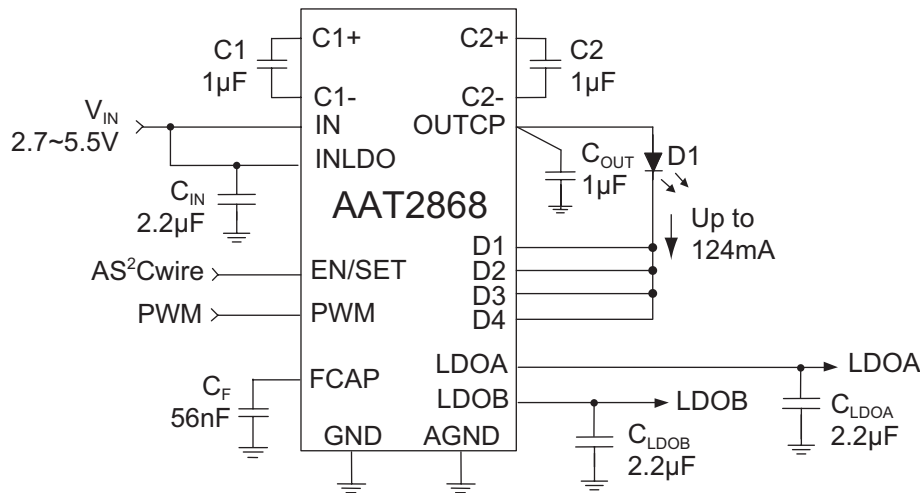

Figure 5: Higher Current, Single LED Application.

Schematic and Layout

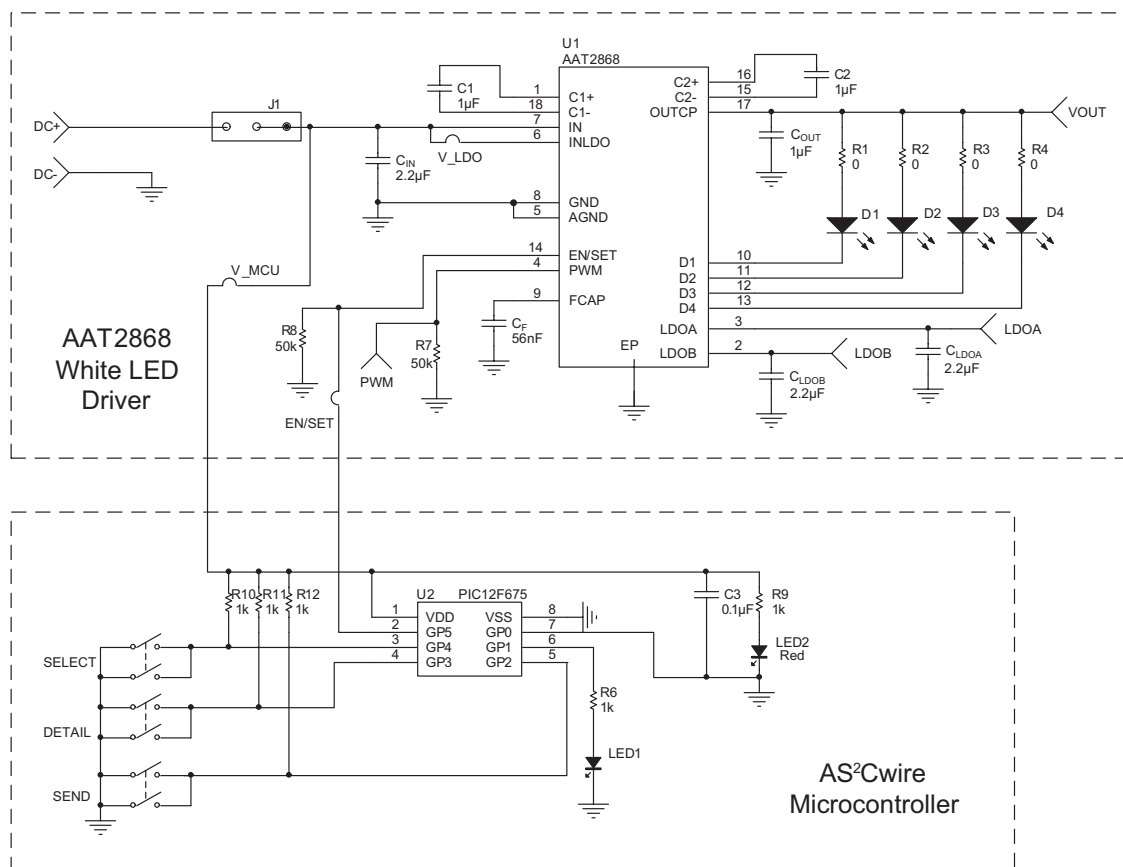

Figure 6: AAT2868 Evaluation Board Schematic.

AAT2868

CABC Compatible Four-Channel Backlight Driver with Dual LDO Regulators

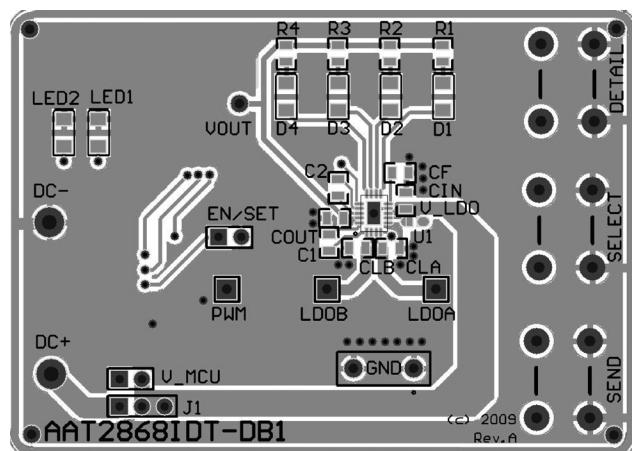

Figure 7: AAT2868 Evaluation Board Top Side Layout.

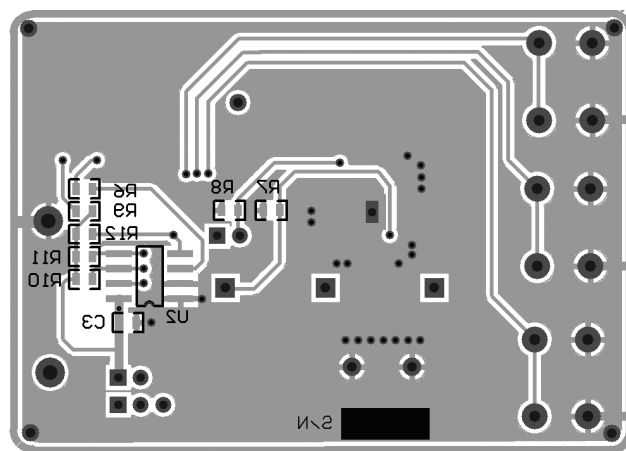

Figure 8: AAT2868 Evaluation Board Bottom Side Layout.

Component	Part Number	Description	Manufacturer
U1	AAT2868IDT-T1	High Efficiency, 4 Channel, 1X/1.5X Charge Pump for White LED	Skyworks
U2	PIC12F675	8-Pin Flash-Based 8-Bit CMOS Microcontroller	Microchip
R1, R2, R3, R4	RC0603FR-070RL	Res 0Ω 1/10W 1% 0603 SMD	Yageo
R7, R8	RC0603FR-0749K9L	Res 49.9KΩ 1/10W 1% 0603 SMD	
R6, R9, R10, R11, R12	RC0603FR-071KL	Res 1KΩ 1/10W 1% 0603 SMD	Murata
C1, C2, COUT	GRM188R71C105K	Cap Ceramic 1μF 0603 X7R 16V 10%	
CIN, CLA, CLB	GRM188R61A225K	Cap Ceramic 2.2μF 0603 X5R 10V 10%	
C3	GRM188R71C104K	Cap Ceramic 0.1μF 0603 X7R 16V 10%	
C _F	GRM188R71C563K	Cap Ceramic 0.056μF 0603 X7R 16V 10%	Realstar
D1, D2, D3, D4	RS-0805UW	20mA White LED 0805	
LED1	0805KGCT	Green LED 0805	
LED2	0805KRCT	Red LED 0805	HB
CYCLE, UP, DOWN	6*6*5	12V 50mA Pushbutton	E-LT

Table 8: AAT2868IDT-DB1 Evaluation Board Bill of Materials.

CABC Compatible Four-Channel Backlight Driver with Dual LDO Regulators**Ordering Information**

Package	Marking ¹	Part Number (Tape and Reel) ²
TQFN 3.0 x 2.2-18L	5CXXY	AAT2868IDT-T1



Skyworks Green™ products are compliant with all applicable legislation and are halogen-free.

For additional information, refer to *Skyworks Definition of Green™*, document number SQ04-0074.

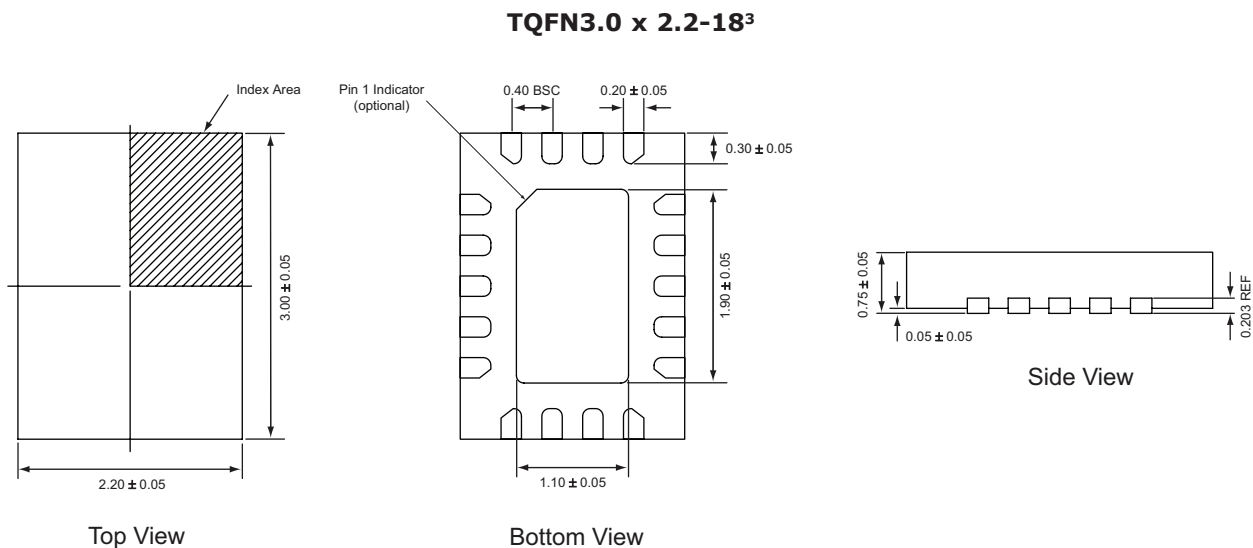
Package Information

All dimensions in millimeters.

1. XYY = assembly and date code.
2. Sample stock is generally held on part numbers listed in **BOLD**.
3. The leadless package family, which includes QFN, TQFN, DFN, TDFN, and STDFN, has exposed copper (unplated) at the end of the lead terminals due to the manufacturing process. A solder fillet at the exposed copper edge cannot be guaranteed and is not required to ensure a proper bottom solder connection.

Copyright © 2012 Skyworks Solutions, Inc. All Rights Reserved.

Information in this document is provided in connection with Skyworks Solutions, Inc. ("Skyworks") products or services. These materials, including the information contained herein, are provided by Skyworks as a service to its customers and may be used for informational purposes only by the customer. Skyworks assumes no responsibility for errors or omissions in these materials or the information contained herein. Skyworks may change its documentation, products, services, specifications or product descriptions at any time, without notice. Skyworks makes no commitment to update the materials or information and shall have no responsibility whatsoever for conflicts, incompatibilities, or other difficulties arising from any future changes.

No license, whether express, implied, by estoppel or otherwise, is granted to any intellectual property rights by this document. Skyworks assumes no liability for any materials, products or information provided hereunder, including the sale, distribution, reproduction or use of Skyworks products, information or materials, except as may be provided in Skyworks Terms and Conditions of Sale.

THE MATERIALS, PRODUCTS AND INFORMATION ARE PROVIDED "AS IS" WITHOUT WARRANTY OF ANY KIND, WHETHER EXPRESS, IMPLIED, STATUTORY, OR OTHERWISE, INCLUDING FITNESS FOR A PARTICULAR PURPOSE OR USE, MERCHANTABILITY, PERFORMANCE, QUALITY OR NON-INFRINGEMENT OF ANY INTELLECTUAL PROPERTY RIGHT; ALL SUCH WARRANTIES ARE HEREBY EXPRESSLY DISCLAIMED. SKYWORKS DOES NOT WARRANT THE ACCURACY OR COMPLETENESS OF THE INFORMATION, TEXT, GRAPHICS OR OTHER ITEMS CONTAINED WITHIN THESE MATERIALS. SKYWORKS SHALL NOT BE LIABLE FOR ANY DAMAGES, INCLUDING BUT NOT LIMITED TO ANY SPECIAL, INDIRECT, INCIDENTAL, STATUTORY, OR CONSEQUENTIAL DAMAGES, INCLUDING WITHOUT LIMITATION, LOST REVENUES OR LOST PROFITS THAT MAY RESULT FROM THE USE OF THE MATERIALS OR INFORMATION, WHETHER OR NOT THE RECIPIENT OF MATERIALS HAS BEEN ADVISED OF THE POSSIBILITY OF SUCH DAMAGE.

Skyworks products are not intended for use in medical, lifesaving or life-sustaining applications, or other equipment in which the failure of the Skyworks products could lead to personal injury, death, physical or environmental damage. Skyworks customers using or selling Skyworks products for use in such applications do so at their own risk and agree to fully indemnify Skyworks for any damages resulting from such improper use or sale.

Customers are responsible for their products and applications using Skyworks products, which may deviate from published specifications as a result of design defects, errors, or operation of products outside of published parameters or design specifications. Customers should include design and operating safeguards to minimize these and other risks. Skyworks assumes no liability for applications assistance, customer product design, or damage to any equipment resulting from the use of Skyworks products outside of stated published specifications or parameters.

Skyworks, the Skyworks symbol, and "Breakthrough Simplicity" are trademarks or registered trademarks of Skyworks Solutions, Inc., in the United States and other countries. Third-party brands and names are for identification purposes only, and are the property of their respective owners. Additional information, including relevant terms and conditions, posted at www.skyworksinc.com, are incorporated by reference.